

MITCHELL CONCRETE SPECIALTIES TRAFFIC RATED GREASE INTERCEPTOR 3000 GALLON - M3000H20CW

Top View

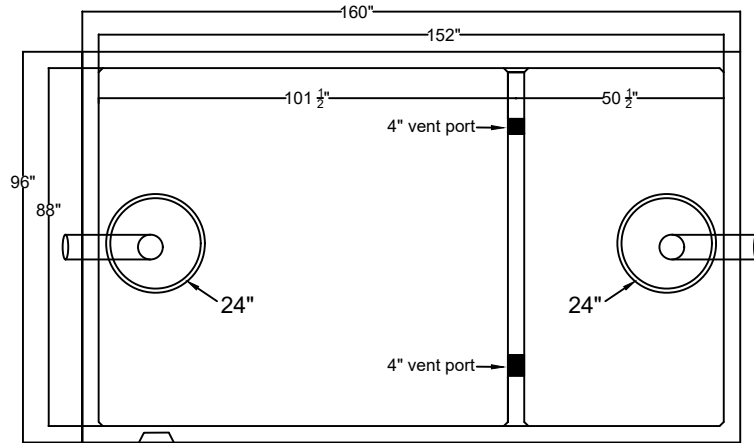

End View

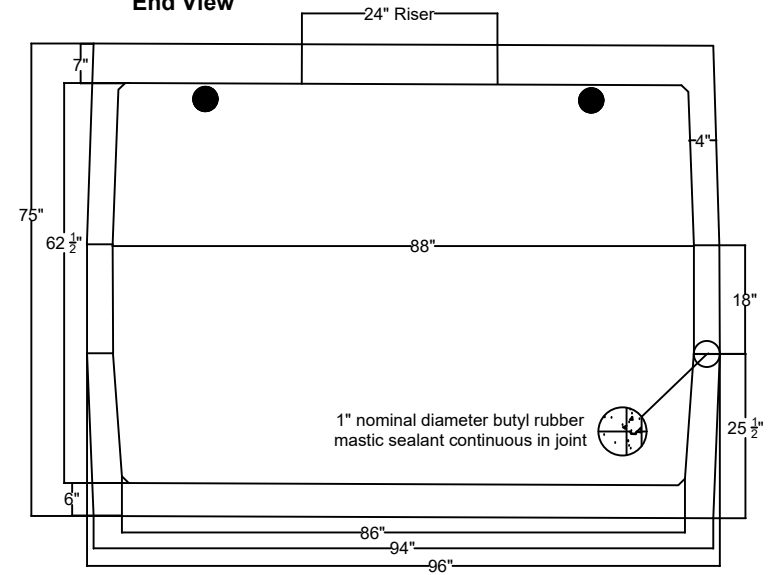

Side View

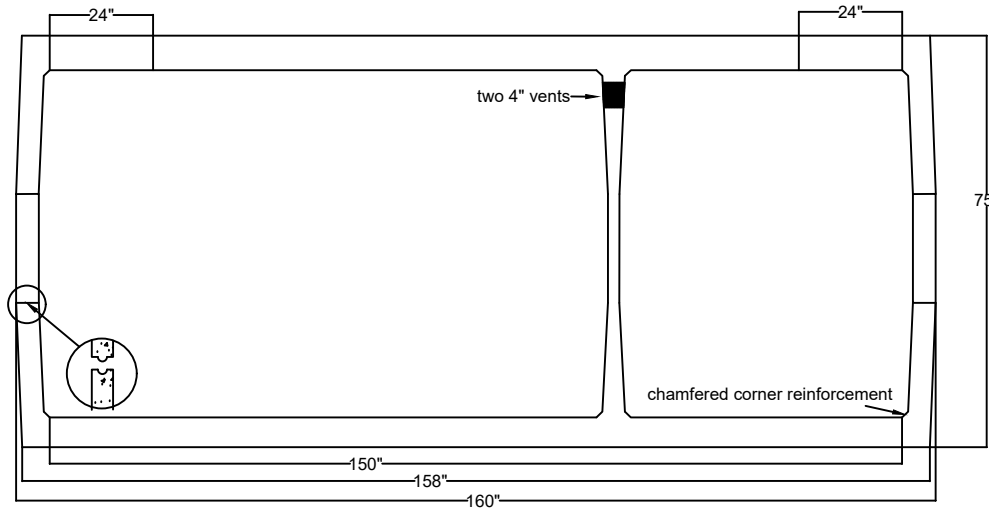

Mitchell Concrete Specialties
499 US Highway 31 South
Alabaster, AL 35007
(205) 663-3652

M3000H20CW Specifications:
Load Rating: H20
Full Capacity: 3,482.5 gallons
Concrete: 5000 psi. fiber reinforced
Total Weight: 29,750 lbs.
Length to Width Ratio: 1.73:1

Reinforcing:
#4, #5 bidirectional rebar cage on top and bottom.
#5 bent rebar added vertically in top and bottom walls, wrapping tank edges and tied to top and bottom cage.
Tank seam reinforced with double continuous rebar rings.
Double #3 rings added around tank top openings.
All rebar is grade 60.

Notes:

- Inlet/Outlet/Crossover/Vent sizing can be customized upon request.
- Optional side inlet/outlets also available
- Optional top venting available
- 6" inlets/outlets shown are also suitable for 4" use
- H20 tanks designed in accordance with ASTM C890 and ACI 318.
- Materials and manufacturing conform to ASTM C1227/C1613