

## MITCHELL CONCRETE SPECIALTIES CAR WASH TANK FRAME 2000 GALLON - M2000H20CW

Top View

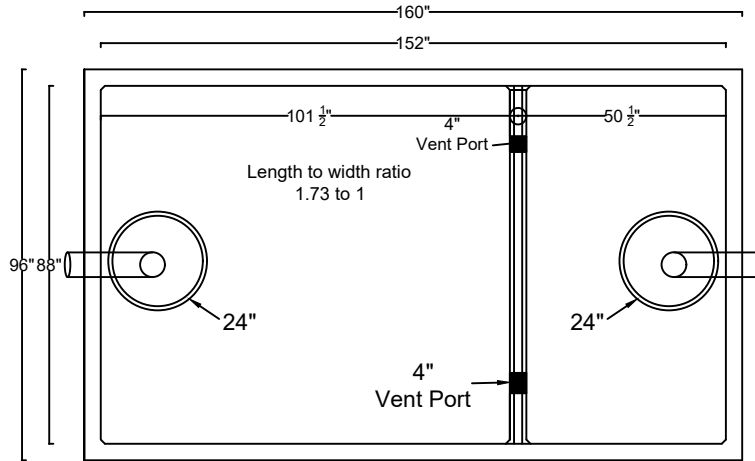

Rubber pressure sealed closed end boots with stainless clamps

Meets ASTM C923

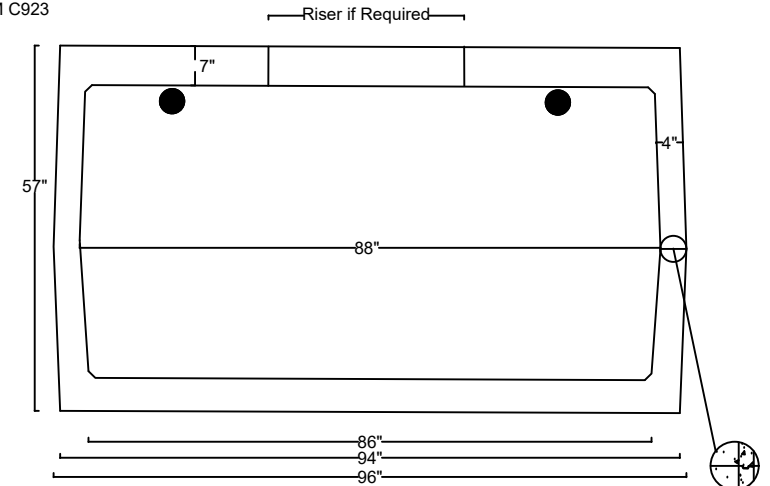

End View

1" Nominal Diameter or equivalent Butyl Rubber Mastic Sealant Continuous in joint

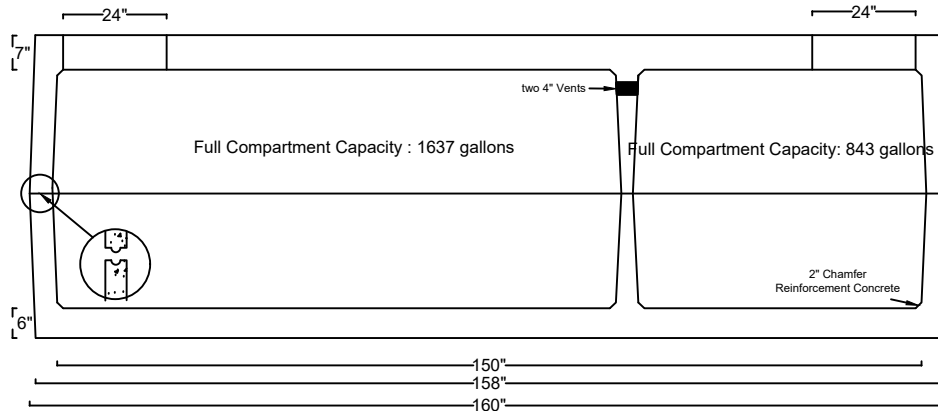

Side View

Mitchell Concrete Specialties  
P.O. Box 36  
Saginaw, AL 35007  
(205) 663-3652

**M2000H20CW Specifications:**  
Load Rating: H20  
Full Capacity: 2,480 gallons  
Concrete: 5000 psi. fiber reinforced  
Tank Weight: 25,750 lbs.

**REINFORCING:** #4, #5 bidirectional rebar cage on top and bottom. #5 bent rebar added vertically in top and bottom walls, wrapping tank edges and tied to the top and bottom cage. Tank seam reinforced with double continuous rebar rings. All rebar is grade 60.

Concrete mix reinforced with synthetic macro fiber.

**Notes:**

- Inlet/Outlet/Crossover/Vent sizing can be customized upon request.
- Optional side inlet/outlets also available
- Optional top venting available